

SERVOMOTORS SMXT1

0.1-0.3 Nm

DIMENSIONS

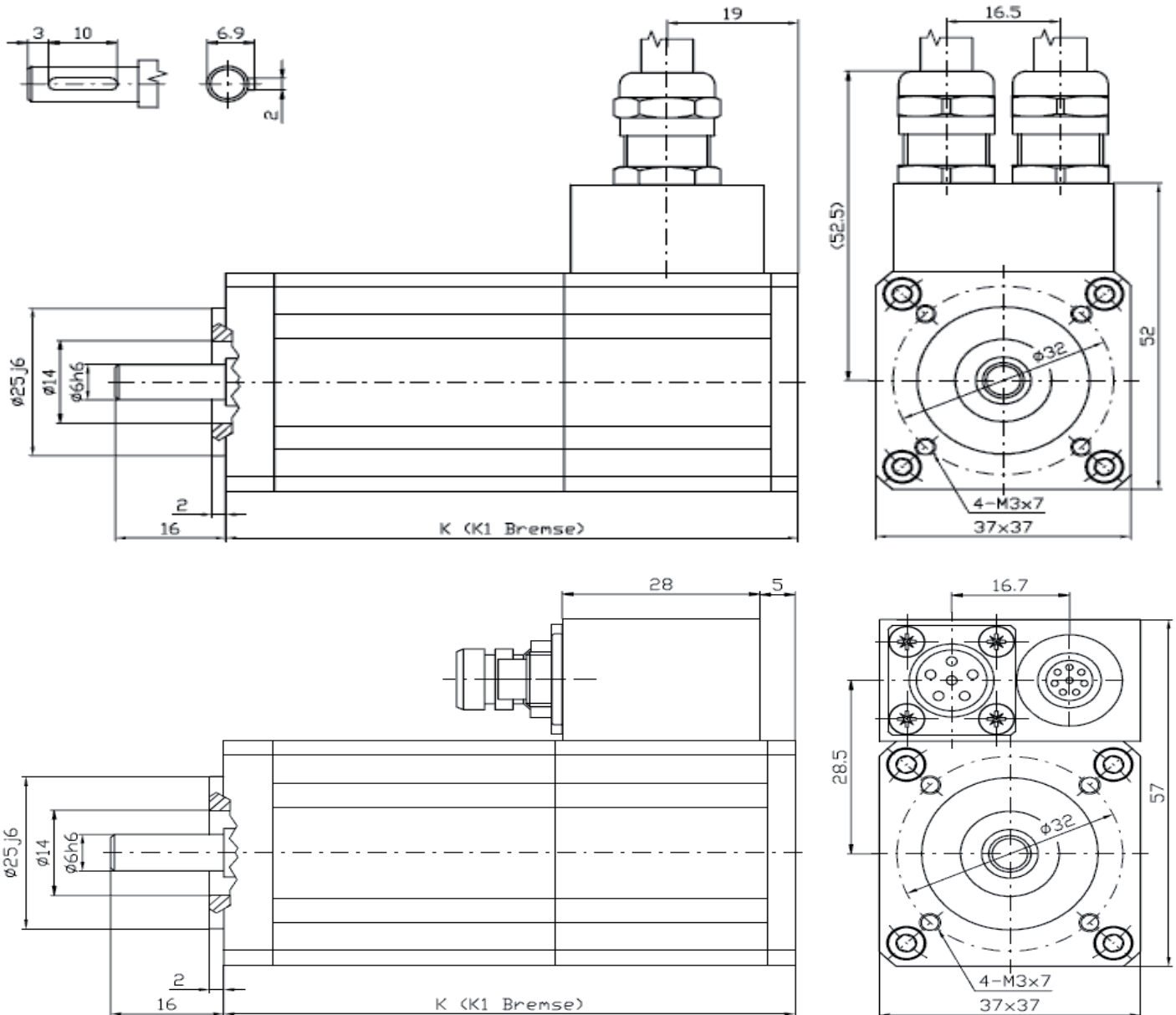

Type	K (resolver)	K1 (resolver+brake)
SMXT1-10	81 mm	111 mm
SMXT1-20	96 mm	126 mm
SMXT1-30	111 mm	141 mm

On request we can send you the technical parameters of the motors designed for different DC-Voltages or speed/torque characteristics. Other adaptations and modifications are possible.