

DIMENSIONS

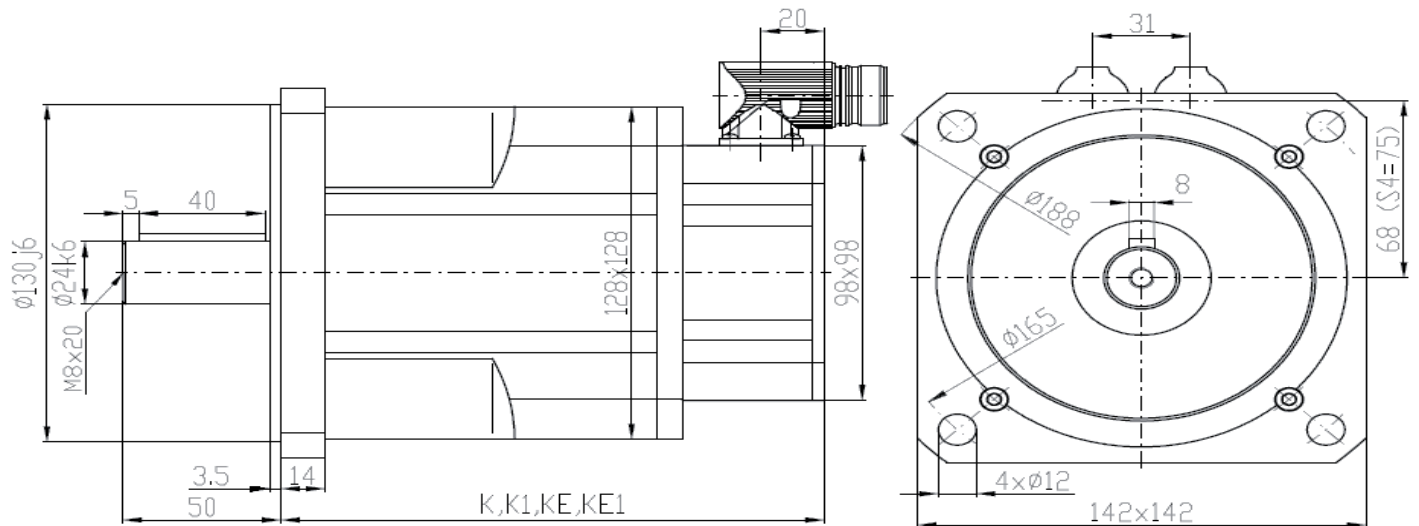

Type	K (resolver)	K1 (resolver+brake)	KE (EnDAT)	KE1 (EnDAT+brake)
SMXH5-1050	173 mm	224 mm	192 mm	243 mm
SMXH5-1350	201 mm	252 mm	220 mm	271 mm
SMXH5-1700	231 mm	282 mm	250 mm	301 mm
SMXH5-2500	291 mm	342 mm	310 mm	361 mm

On request we can send you the technical parameters of the motors designed for different DC-Voltages or speed/torque characteristics. Other adaptations and modifications are possible.