

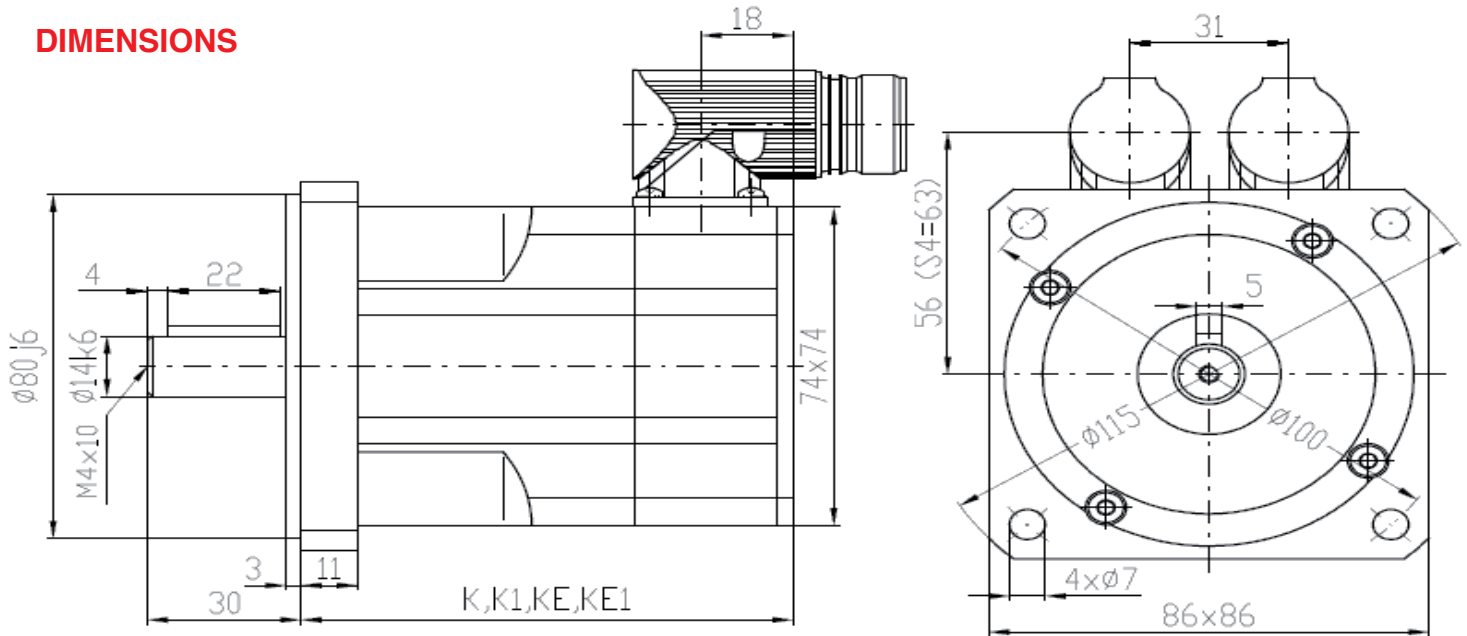

# SERVOMOTORS SMXH3

0.8-3.5 Nm

## DIMENSIONS



Type	K (resolver)	K1 (resolver+brake)	KE (EnDAT)	KE1 (EnDAT+brake)
SMXH3-080	95 mm	140 mm	137 mm	179 mm
SMXH3-160	113 mm	158 mm	155 mm	197 mm
SMXH3-270	149 mm	194 mm	191 mm	233 mm
SMXH3-350	168 mm	228 mm	227 mm	269 mm

On request we can send you the technical parameters of the motors designed for different DC-Voltages or speed/torque characteristics. Other adaptations and modifications are possible.