

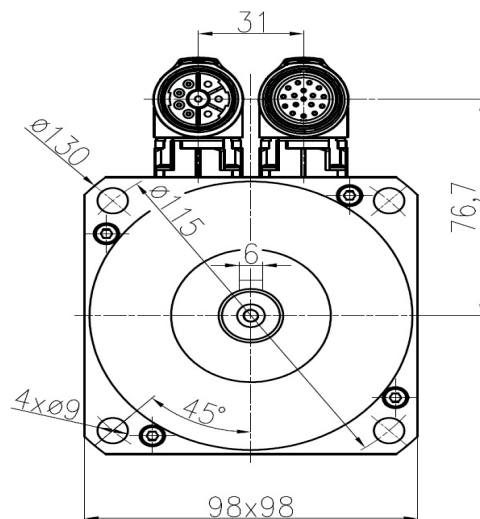

# SERVOMOTORS SMXN4

## 5.1-11.3 Nm

### DIMENSIONS

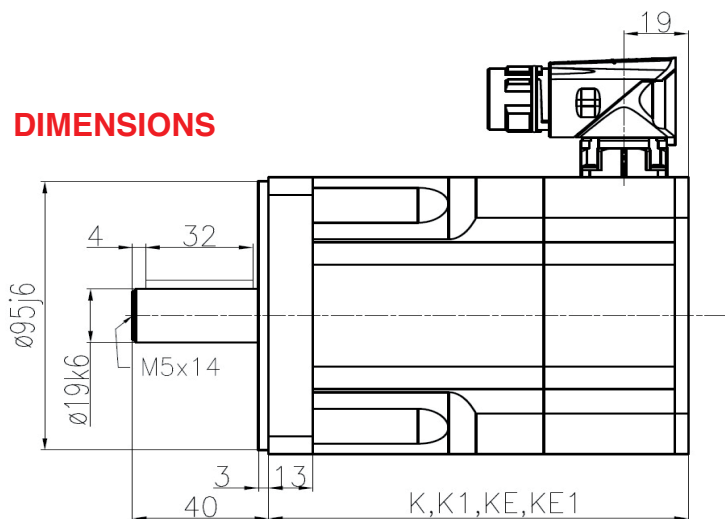

Type	K (Resolver)	K1 (Resolver+brake)	KE (EnDAT)	KE1 (EnDAT+brake)
SMXN4-510	113 mm	154 mm	150 mm	191 mm
SMXN4-750	143 mm	184 mm	180 mm	221 mm
SMXN4-960	173 mm	214 mm	210 mm	251 mm
SMXN4-1130	203 mm	244 mm	240 mm	281 mm

Length of motor with Hiperface sensor is the same like length of motor with EnDat sensor. In some types of motor can be smaller.

Servomotors with one integrated connector

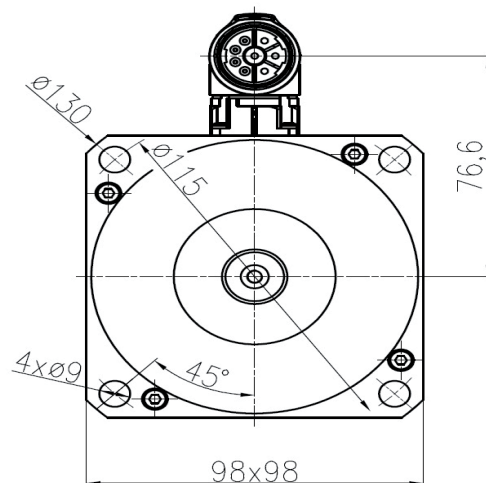
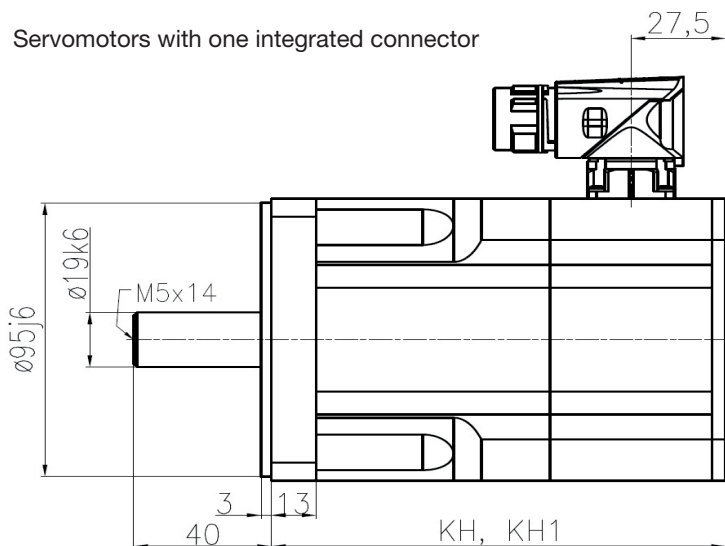

Type	KH (DSL)	KH1 (DSL+brake)
SMXN4-510	132 mm	182,5 mm
SMXN4-750	162 mm	212,5 mm
SMXN4-960	192 mm	242,5 mm
SMXN4-1130	222 mm	272,5 mm

On request we can send you the technical parameters of the motors designed for different DC-Voltages or speed/torque characteristics. Other adaptations and modifications are possible.