

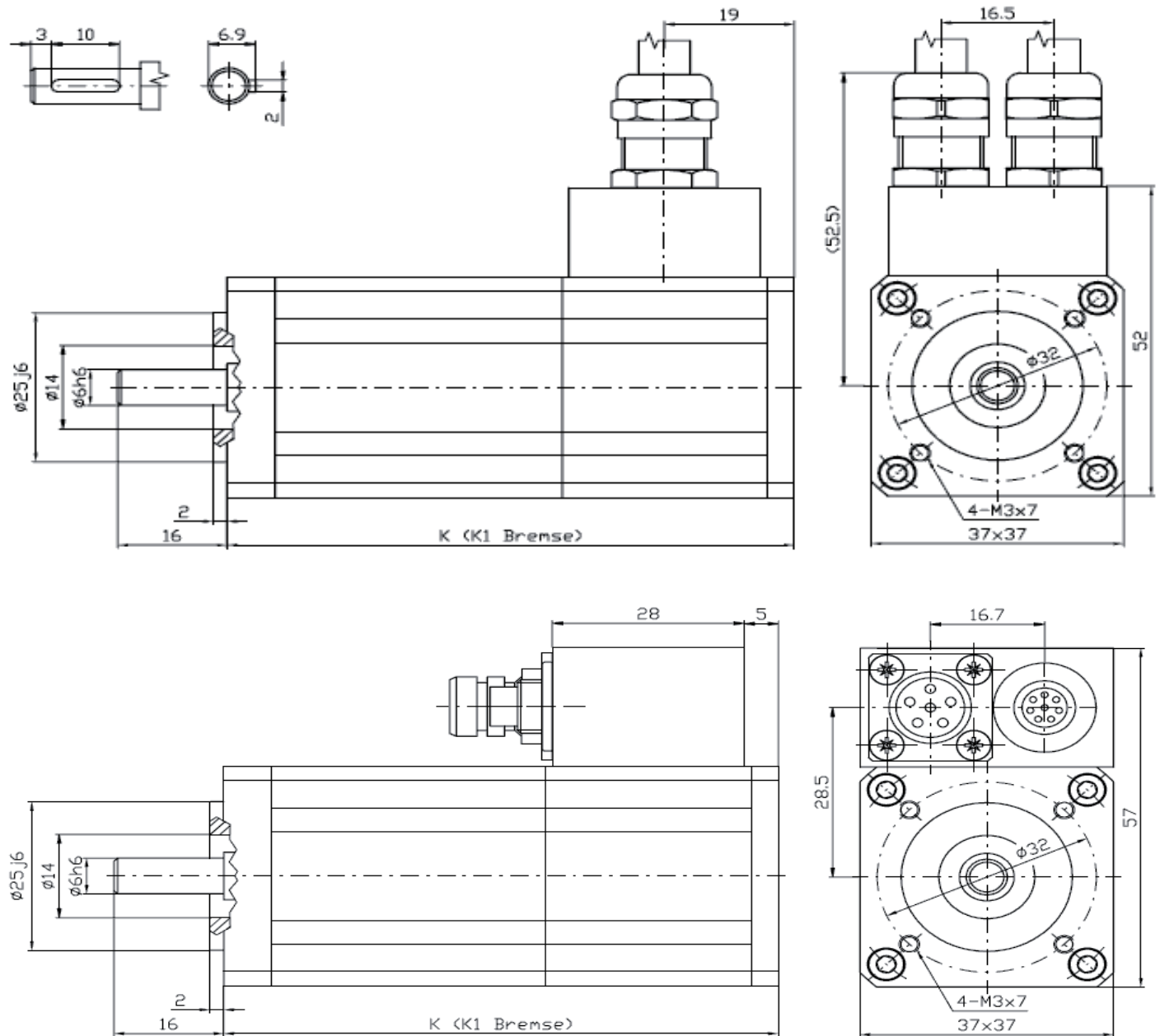

**DIMENSIONS**



| Type      | K      | K1 (brake) |
|-----------|--------|------------|
| SMXN1-010 | 81 mm  | 111 mm     |
| SMXN1-020 | 96 mm  | 126 mm     |
| SMXN1-030 | 111 mm | 141 mm     |

On request we can send you the technical parameters of the motors designed for different DC-Voltages or speed/torque characteristics. Other adaptations and modifications are possible.